

GUARD RAIL CONNECTION DETAIL
SEE HIGHWAY GUARD RAIL (MASH) STANDARD PLANS FOR MORE INFORMATION

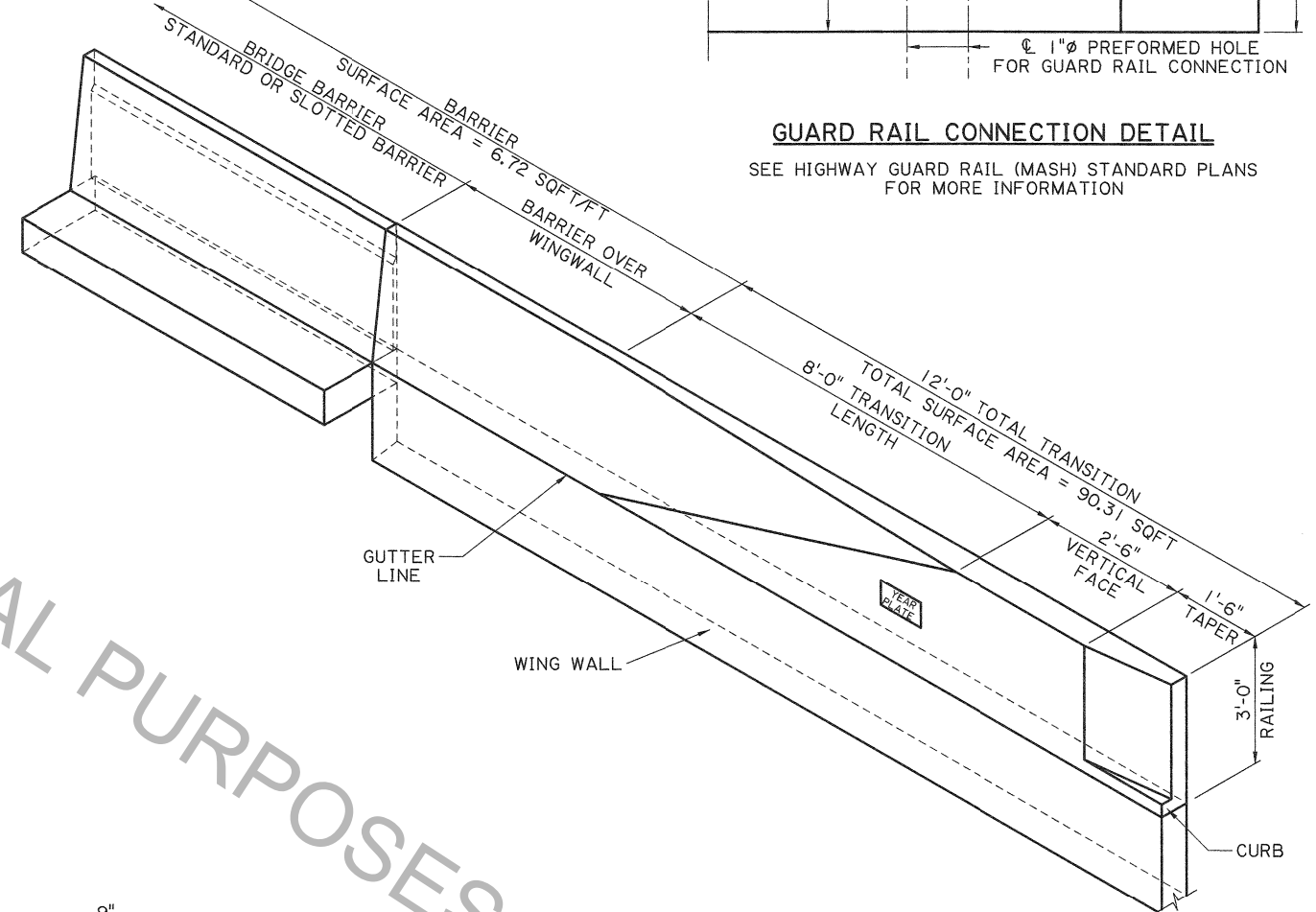

BARRIER RAILING TRANSITION ELEVATION
SECTIONS (SEE BELOW)

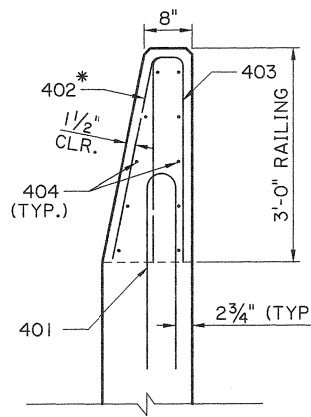

BARRIER OVER WINGWALL AND START OF TRANSITION

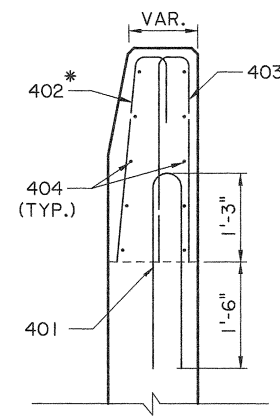

BEFORE 50% TRANSITION

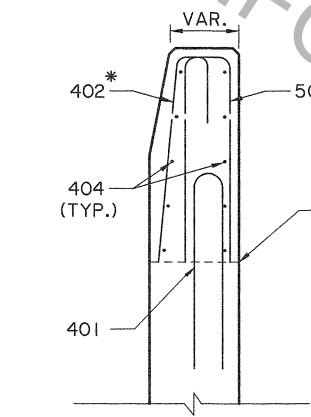

AFTER 50% TRANSITION

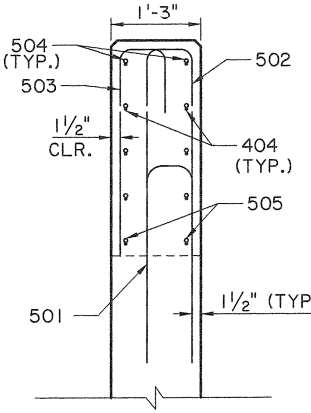

VERTICAL FACE

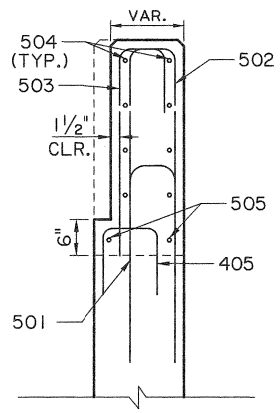

TAPER

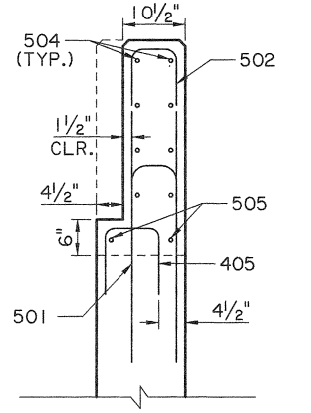

END OF BARRIER

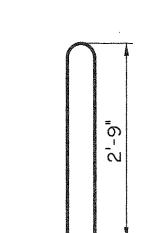

BAR 401
(3 3/4" Ø PIN)

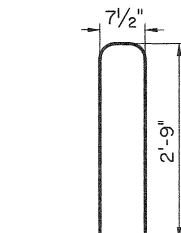

BAR 501
(3 3/4" Ø PIN)

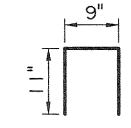

BAR 405
(2" Ø PIN)

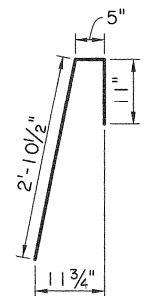

BAR 402
(2" Ø PIN)

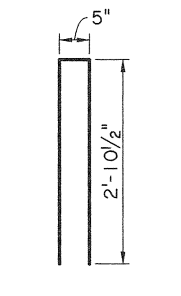

BAR 403
(2" Ø PIN)

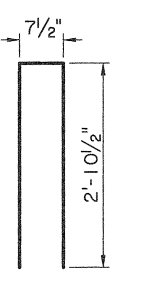

BAR 502
(2 1/2" Ø PIN)

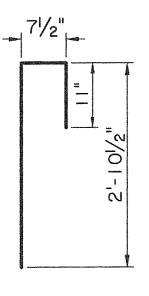

BAR 503
(2 1/2" Ø PIN)

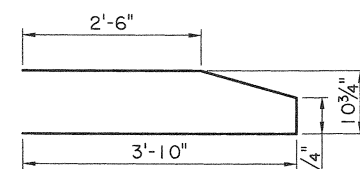

BAR 504
(2 1/2" Ø PIN)

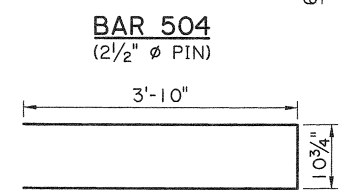

BAR 505
(2 1/2" Ø PIN)

- NOTES:**
- SEE "BRIDGE BARRIER COMMON - GENERAL NOTES & INDEX" SHEET FOR GENERAL BRIDGE BARRIER NOTES.
 - CURB SHALL BE POURED MONOLITHIC WITH BARRIER.
 - ADJUST ANGLE OF LEG AS NEEDED TO MAINTAIN MIN. COVER AT FACE OF BARRIER.

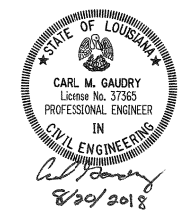

FOR INFORMATIONAL PURPOSES ONLY

SHEET NUMBER	
DESIGNED	S. MAZUR
CHECKED	C. GAUDRY
CONTROL SECTION	
STATE PROJECT	
REVISION OR CHANGE ORDER DESCRIPTION	
NO.	
DATE	
BY	
PARISH	
CONTROL SECTION	
STATE PROJECT	
DESIGNED	S. MAZUR
CHECKED	C. GAUDRY
CONTROL SECTION	
STATE PROJECT	
REVISION OR CHANGE ORDER DESCRIPTION	
NO.	
DATE	
BY	
PARISH	
CONTROL SECTION	
STATE PROJECT	
DESIGNED	S. MAZUR
CHECKED	C. GAUDRY
CONTROL SECTION	
STATE PROJECT	
REVISION OR CHANGE ORDER DESCRIPTION	
NO.	
DATE	
BY	
PARISH	
CONTROL SECTION	
STATE PROJECT	
DESIGNED	S. MAZUR
CHECKED	C. GAUDRY
CONTROL SECTION	
STATE PROJECT	
REVISION OR CHANGE ORDER DESCRIPTION	
NO.	
DATE	
BY	
PARISH	
CONTROL SECTION	
STATE PROJECT	
DESIGNED	S. MAZUR
CHECKED	C. GAUDRY
CONTROL SECTION	
STATE PROJECT	
REVISION OR CHANGE ORDER DESCRIPTION	
NO.	
DATE	
BY	
PARISH	
CONTROL SECTION	
STATE PROJECT	

TRANSITION ON WING WALL
36" SINGLE SLOPE BRIDGE BARRIER